

DE LASER_____

Electronic Digital Theodolite

OPERATOR'S MANUAL

Precaution

- 1) If the instrument has not been used for a long time, check it regularly (3 months).
- 2) Avoid shocking or bumping.
- 3) No using in high dusty, not well ventilated, and easy burning environment.
- 4) No dismount and mount the instrument by yourselves.
- 5) Prohibit to see the sun with telescope.
- 6) Cover with umbrella in burning sun or rainy day.
- 7) Cover the instrument with rainy cover.
- 8) Power off before taking off battery, or the data will be lost.
- 9) Place instrument the case and avoid humidity.
- 10) Prohibit move the instrument with tripod.
- 11) It will cause measuring result is not correct if there is leaves and obstacle between the target and the instrument.
- 12) Place the instrument like the picture below:



- 13) Contact me if you got any problem.

Declaration

We won't afford any responsibility if following conditions occur:

- 1) Damage caused by drop, extrusion, soaking, wetting and other man-made damage.
- 2) Cycle inspection, protection, repair or component replacement caused by normal abrasion.
- 3) Damage caused flood, fire, lighting stroke and other natural disaster.
- 4) Malfunction of products due to not following protection instruction of product instruction book.
- 5) The instrument that has been repaired by repair center having no authority won't be accepted by us.

Contents

1. Description of All Parts	1
1.1 Name of Parts.....	1
1.2 Display.....	2
1.3 Operation Key.....	3
1.4 Function Key.....	3
1.5 RS 232.....	4
2. Battery	5
2.1 Battery Replacement.....	5
2.2 Battery Recharging.....	5
3. Measurement Preparation	5
3.1 Instrument Setting Up.....	5
3.2 Instrument Leveling.....	6
3.3 Centering with Optical Plummet.....	6
3.4 Eyepiece Adjustment and Object Sighting.....	6
3.5 Power on.....	6
3.6 Power off.....	7
3.7 Input Numbers.....	7
3.8 Turn on / off Compensator (Tilt)	8
4. Angle Measurement	10
4.1 Measuring Horizontal Angle Right and Vertical Angle.....	10
4.2 Switching Horizontal Angle Right/Left.....	11
4.3 Setting Horizontal Angle.....	11
4.4 Vertical Angle Percent Grade (%) Mode.....	12
4.5 Compasses (vertical angle)	13
4.6 Remeasuring Horizontal Angle.....	13
5. Distance Measurement	14
6. Distance Measurement through the crossline in the telescope	15
7. Laser Measurement	15
7.1 Orientation Measurement.....	15
7.2 Angle Designment.....	15
7.3 Zeith Measurement.....	16
7.4 Level Measurement.....	16
8. Parameter Setting Up	16
8.1 Enter into Setting up Parameter.....	16
8.2 Setting up Power off Automatically.....	17
8.3 Setting up Position 0(Vertical Angle)	17
8.4 Setting up Compensator	17
8.5 Setting up Angle Unit	18
8.6 Setting up Minimum Reading	18
8.7 Setting up Distance Unit	19
8.8 Saving Setup.....	19
8.9 Contrast Adjusting.....	20

9. Check & Adjustment	20
9.1 Check & Adjustment of Plate Vial.....	20
9.2 Check & Adjustment of Circular Vial	21
9.3 Check & Adjustment of Optical Plummet.....	21
9.4 Check & Adjustment of Inclination of Reticle.....	22
9.5 Check & Adjustment of discrepancy between twice collimation errors(C)	22
9.6 Check & Adjustment of Vertical Index(i angle)	23
9.7 Check & Adjustment of the laser confocal and coaxial.....	24
10. Technical Index	24
11. Packing List	25

1. Description of All Parts

1.1 Name of Parts

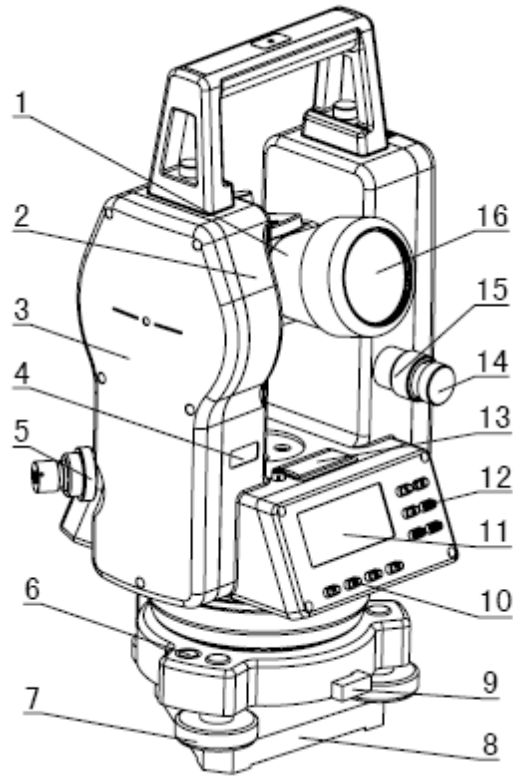

1. Telescope	9. Connection Knob on Tribrach
2. Main body	10. Soft Key
3. Left Side Cover	11. Display
4. Series No.	12. Function Key
5. Optical Plummet	13. Plate Vial
6. Circular Vial	14. Vertical Tangent Screw
7. Leveling Screw	15. Vertical Clamp Screw
8. Tribrach	16. Objective Lens

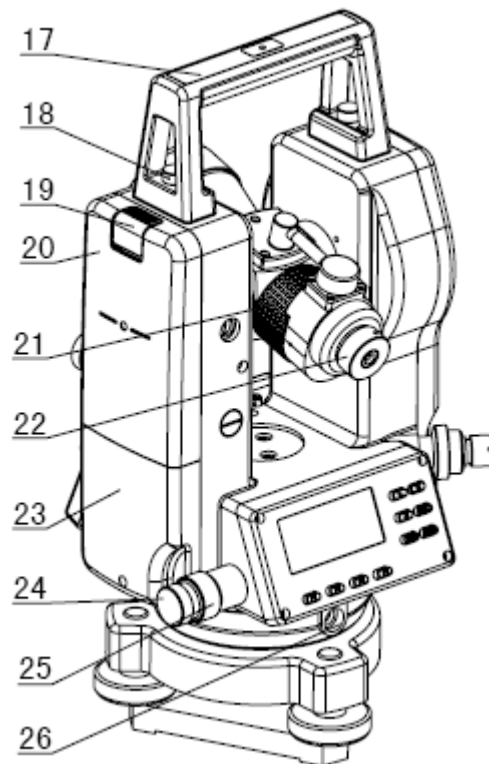

17. Handle	22. Eyepiece
18. Handle Screw	23. Right Side Cover
19. Battery locking Lever	24. Horizontal Tangent crew
20. Battery	25. Horizontal Clamp Screw
21. Grip	26. RS232 Port

1.2 Display

The dot matrix LCD can display 4 lines of characters and numbers. Each Line can display 20 characters. Normally the first 3 lines show measured data while the last line shows the function of the measurement mode.

There are two modes on display: Measurement Mode & Menu Mode.

◆ Display(example):

V ↑ :	81° 54' 21"
HR :	157° 33' 58"
OSET	HOLD HSET P1 ↓

Mode of Angle Measurement

Vertical angle: 81°54'21"

Horizontal angle: 157°33'58"

V ↑ :	81° 54' 21"
HR :	157° 33' 58"
SD :	130.216m
CT	TR SD/HD STOP

Mode of Distance Measurement 1

Vertical angle: 81°54'21"

Horizontal angle: 157°33'58"

Slant Distance: 130.216 m

HR	:	157° 33' 58"	0
Sum	:	0° 00' 00"	
Average:		0° 00' 00"	
>Sight A	?	ENTER	

Mode of Remeasurement

Horizontal angle: 157°33'58"

Sum: 0°00'00"

Average: 0°00'00"

MENU		2-1
F1:	LASER UP	[OFF]
F2:	LCD	[OFF]
F3:	CONTRAST ADJ	P ↓

Mode of MEAU 1

F1: LASER UP[OFF]

F2: LCD[OFF]

F3: CONTRAST ADJ

◆ Symbol Display

Symbol	Contents
V↑	Mode in which zenith of vertical angle is 0
V→	Mode in which horizontal of vertical angle is 0
%	Gradient Display
HR	H-angle right
HL	H-angle left
OUT	slope is over ±100%
° ' "	Set 360° as angle unit
GON (g)	Set 400 gon as angle unit
MIL	Set 6400 mil as angle unit
m	Meter unit
ft	Feet unit

1.3 Operation Key

Key	Function
F1~F4	Function of fourth line
ESC	Escape
⊙	Power on/off
MENU	Enter into main menu
↵	Enter into Remeasurement
	Enter into Distance Measurement
ANG	Enter into Angle Measurement

1.4 Function Key

The fourth line on screen is Function Key, which differs from the different measurement mode.

Mode of Angle Measurement

V ↑ :	81° 54' 21"		
HR :	157° 33' 58"		
OSET	HOLD	HSET	P1 ↓

↓ ↓ ↓ ↓
F1 F2 F3 F4

V ↑ :	81° 54' 21"		
HR :	157° 33' 58"		
TILT	V/%	R/L	P2 ↑

↓ ↓ ↓ ↓
F1 F2 F3 F4

Page	Function Key	Symbol Display	Function
Page 1 (P1)	F1	0SET	Set horizontal angle as 0°00'00"
	F2	HOLD	Hold the horizontal angle
	F3	HSET	Set a required horizontal angle by entering numerals
	F4	P1↓	The function of soft keys is shown on next page(P2)
Page 2 (P2)	F1	TILT	Setting tilt correction.If On. The display shows tilt correction value.
	F2	V/%	Vertical angle percent grade(%) mode
	F3	R/L	Switches R/L rotation of horizontal angle
	F4	P2↑	The function of soft keys is shown on next page(P1)

Mode of Distance Measurement

V ↑ :	81° 54' 21"
HR :	157° 33' 58"
SD :	130.216m
CT TR SD/HD STOP	

V ↑ :	81° 54' 21"
HD :	30.216m
SD :	130.216m
CT TR SD/HD STOP	

Function Key	Symbol Display	Function
F1	CT	Enter into Fine Measurement
F2	TR	Enter into Tracking Measurement
F3	SD/HD	Switches HD/SD/HD
F4	STOP	Stop Measuring

Mode of MENU

MENU	2-1
F1: LASER UP[OFF]	
F2: LCD[OFF]	
F3: CONTRAST ADJ	P ↓

Function Key	Symbol Display	Function
F1	LASER UP[OFF]	Turn ON/OFF Laser
F2	LCD[OFF]	Turn ON/OFF LCD
F3	CONTRAST ADJ	Enter into Contrast Adjustment

1.5 RS232

RS232 is used to connect the Theodolite with computer or PC to transfer measured data to computer or PC.

2. Battery

2.1 Battery Replacement

1. Battery Insert

Insert battery correctly. Check and insert battery holder true to side into the housing.



2. Battery Removal Remove battery and replace.

2.2 Battery Recharging

1. Insert recharger into battery's hole.



2. Insert the plug of the recharger into 220V AC power supply. It shows green light after finishing recharging.

3. Cut the power supply of the recharger and draw the battery out from the recharger.

Notes:

1. It's recharging when the red light shows.
2. Normally it takes 7 hours for recharging, but it must be 12-15 hours for the first time.
3. Recharging temperater: $0^{\circ}\text{C} \sim \pm 45^{\circ}\text{C}$.
4. Recharging times: 300—500 times.

3. Measurement Preparation

3.1 Instrument Setting Up

1. Setting up the tripod. Pull out to required length and tighten screws.

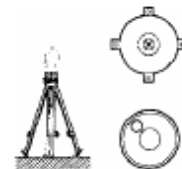

2. Place the INSTRUMENT onto the tripod head. Tighten central fixing screw of tripod.

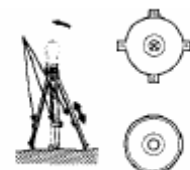

3.2 Instrument leveling

1. Level the instrument with circular vial

a. Turn the leveling screw A and B to move the bubble in the circular vial. The bubble is now located on a line perpendicular to a line running through the centers of the two leveling screws being adjusted.

b. Turn the leveling screw C to bring the bubble to the center of the circular vial.

2. Level the instrument with plate vial

a. Rotate the instrument horizontally by loosening the Horizontal Clamp Screw and place the plate vial parallel with the line connecting leveling screw A and B, and then bring the bubble to the center of the plate vial by turning the leveling screws A and B.

b. Rotate the instrument 90° (100g) around its vertical axis and turn the remaining leveling screw or leveling C to center the bubble once more.

c. Repeat the procedures 1 & 2 for each 90° (100g) rotation of the instrument and check whether the bubble is correctly centered for all four points.

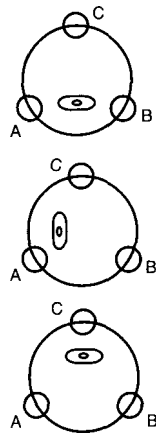

3.3 Centering by optical plummet

Adjust the eyepiece of the optical plummet telescope to your eyesight. Slide the instrument by loosening the tripod screw, place the point on the center mark of the optical plummet. Sliding the instrument carefully not to rotate that allows you to get the least dislocation of the bubble.

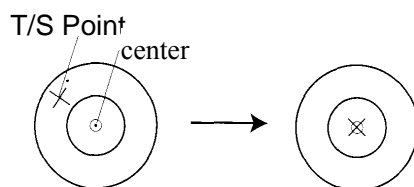

Note: Centering by foot screw first and then leveled up by tripod.

3.4 Eyepiece Adjustment and Object Sighting

1. Sight the Telescope to the sky and rotate the eyepiece tube to make the reticle clear.

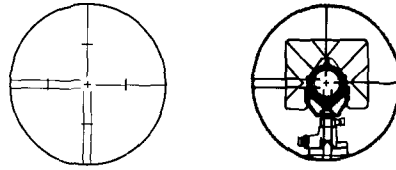

2. Make the target image clear with the telescope focusing screw. If there parallax when your eye move up, down or left, right, that show the diopter of eyepiece lens or focus is not adjusted well and accuracy will be influenced, so you should adjust the eyepiece tube carefully to eliminate the parallax.

3.5 Power on

1. Leveling INSTRUMENT
2. Push the Power key (green).
3. Turn telescope to initial the INSTRUMENT. Confirm the battery is full, if not so, please replace and recharge the battery.

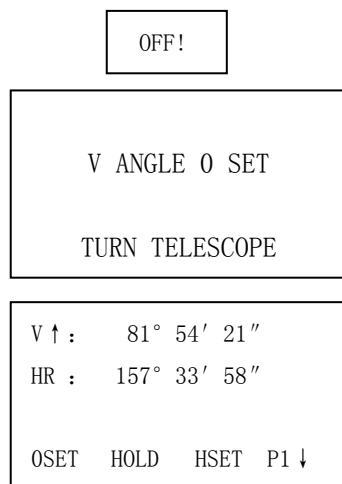

3.6 Power off

Push the Power key (green).

3.7 Input Numbers

Input the angle under the Angle Measurement Mode

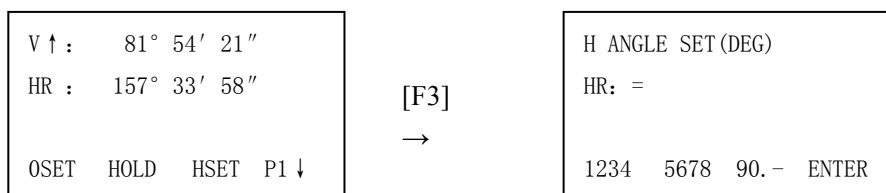

[Example]: Input 190°59'43"

Press [F1]、 [F1] input1

Press [F3]、[F1] input9
 Press [F3]、[F2] input0
 Press [F3]、[F3] input.
 Press [F2]、[F1] input5
 Press [F3]、[F1] input9
 Press [F1]、[F4] input4
 Press [F1]、[F3] input3
 Press [F4] (ENTER), HR is 190°59'43"

Note: Use . between degree and minute but not between minute and second.Press ENTER after inputting numbers, it shows degree minute and second automatically.

3.8 Turn on/off Compensator (Tilt)

When the compensator is activities, automatic correction of vertical angle for mislevelment is displayed. To ensure a precise angle measurement, compensator must be turned on. The display can also be used to fine level the instrument. If the (TILT OVER) display appears the instrument is out of the automatic compensation range and must be leveled manually.

When the instrument is on an unstable stage or a windy day the display of vertical angle is unstable. You can turn off the auto tilt correction function of vertical angle in this case.

[Example 1] : Setting Tilt off/on. (It is saved after powering off.)

Operation Procedure	Display																
<p>① Press [MENU] to enter into main menu 2-1 in the mode of angle measurement</p> <p>Press [F4] to enter into main menu 2-2.</p>	<table border="1" style="width: 100%;"> <tr> <td>MENU</td> <td style="text-align: right;">2-1</td> </tr> <tr> <td>F1: LASER UP[OFF]</td> <td></td> </tr> <tr> <td>F2: LCD[OFF]</td> <td></td> </tr> <tr> <td>F3: CONTRAST ADJ</td> <td style="text-align: right;">P ↓</td> </tr> </table> <table border="1" style="width: 100%;"> <tr> <td>MENU</td> <td style="text-align: right;">2-2</td> </tr> <tr> <td>F1: SET</td> <td></td> </tr> <tr> <td>F2: LASER DOWN[OFF]</td> <td></td> </tr> <tr> <td>F3: EXIT</td> <td style="text-align: right;">P ↑</td> </tr> </table>	MENU	2-1	F1: LASER UP[OFF]		F2: LCD[OFF]		F3: CONTRAST ADJ	P ↓	MENU	2-2	F1: SET		F2: LASER DOWN[OFF]		F3: EXIT	P ↑
MENU	2-1																
F1: LASER UP[OFF]																	
F2: LCD[OFF]																	
F3: CONTRAST ADJ	P ↓																
MENU	2-2																
F1: SET																	
F2: LASER DOWN[OFF]																	
F3: EXIT	P ↑																
<p>② Press [F1] to enter into parameter setting page 3-1</p>	<table border="1" style="width: 100%;"> <tr> <td>SET MENU</td> <td style="text-align: right;">3-1</td> </tr> <tr> <td>F1: POWER AUTO[OFF]</td> <td></td> </tr> <tr> <td>F2: CMPS[V ↑ :]</td> <td></td> </tr> <tr> <td>F3: TILT[OFF]</td> <td style="text-align: right;">P ↓</td> </tr> </table>	SET MENU	3-1	F1: POWER AUTO[OFF]		F2: CMPS[V ↑ :]		F3: TILT[OFF]	P ↓								
SET MENU	3-1																
F1: POWER AUTO[OFF]																	
F2: CMPS[V ↑ :]																	
F3: TILT[OFF]	P ↓																
<p>③ Press [F3] to set compensator as [OFF] or [ON]</p>	<table border="1" style="width: 100%;"> <tr> <td>SET MENU</td> <td style="text-align: right;">3-1</td> </tr> <tr> <td>F1: POWER AUTO[OFF]</td> <td></td> </tr> <tr> <td>F2: CMPS[V ↑ :]</td> <td></td> </tr> <tr> <td>F3: TILT[OFF]</td> <td style="text-align: right;">P ↓</td> </tr> </table>	SET MENU	3-1	F1: POWER AUTO[OFF]		F2: CMPS[V ↑ :]		F3: TILT[OFF]	P ↓								
SET MENU	3-1																
F1: POWER AUTO[OFF]																	
F2: CMPS[V ↑ :]																	
F3: TILT[OFF]	P ↓																

<p>④ Press [F4] twice to enter into parameter setting MENU Page 3-3</p> <p>Press [F1] to save and escape</p>	<div style="border: 1px solid black; padding: 5px; margin-bottom: 10px;"> SET MENU 3-3 F1: SAVE AND EXIT P ↓ </div> <div style="border: 1px solid black; padding: 5px;"> MENU 2-2 F1: SET F2: LASER DOWN[OFF] F3: EXIT P ↑ </div>
--	---

[Example 2]: Setting Tilt correction (It isn't saved after powering off.)

Operation Procedure	Display
<p>① Press [F4] to enter into angle measurement mode (Page 2) in the mode of angle measurement.</p>	<div style="border: 1px solid black; padding: 5px;"> V ↑ : 81° 54' 21" HR : 157° 33' 58" TILT V/% R/L P2 ↑ </div>
<p>② Press[F1] (TILT)</p>	<div style="border: 1px solid black; padding: 5px;"> TILT SENSOR [X-OFF] X: X-ON X-OFF ---- ENTER </div>
<p>③ Press [F1] or [F2] to select compensator [ON] or [OFF].It shows tilt value if the compensator was ON.</p>	<div style="border: 1px solid black; padding: 5px;"> TILT SENSOR [X-ON] X: 0° 00' 30" X-ON X-OFF ---- ENTER </div>
<p>④ Press [F4] (ENTER) to escape.</p>	<div style="border: 1px solid black; padding: 5px;"> V ↑ : 81° 54' 21" HR : 157° 33' 58" TILT V/% R/L P2 ↑ </div>

Note: It shows E108 if the compensator is bad,it needs to return for repairing.

4. Angle Measurement

4.1 Measuring Horizontal Angle Right and Vertical Angle

Make sure the mode is in Angle Measurement.

Operation Procedure	Display
① Aim at the first target A	<div style="border: 1px solid black; padding: 5px;"> V ↑ : 81° 54' 21" HR : 157° 33' 58" OSET HOLD HSET P1 ↓ </div>
② Set horizontal reading of target A as 0°00'00" Press[F1] (0 SET) and [F3] (YES)	<div style="border: 1px solid black; padding: 5px; margin-bottom: 5px;"> H ANGLE 0 SET >OK? --- --- [YES] [NO] </div> <div style="border: 1px solid black; padding: 5px;"> V ↑ : 81° 54' 21" HR : 0° 00' 00" OSET HOLD HSET P1 ↓ </div>
③ Aim at the second target B. The required V/H angle to target B will be displayed.	<div style="border: 1px solid black; padding: 5px;"> V ↑ : 70° 54' 21" HR : 57° 33' 58" OSET HOLD HSET P1 ↓ </div>

How to Collimate (Reference):

1. Point the telescope toward the light. Turn the diopter ring and adjust the diopter so that the cross hairs are clearly observed. (Turn the diopter toward you first and then backward to focus).
2. Aim the target at the peak of the triangle mark of the sighting collimator. Allow a certain space between the sighting collimator and yourself for collimating.
3. Focus the target with the focusing knob. If parallax is created between the cross hairs and the target when viewing vertically or horizontally while looking into the telescope, focusing is incorrect or diopter adjustment is poor. This adversely affects precision in measurement or survey; eliminate the parallax by carefully focusing and using diopter adjustment.

4.2 Switching Horizontal Angle Right/Left

Make sure the mode is Angle measurement

Operation Procedure	Display
① Press [F4] (P1↓) to enter into mode of angle measurement 2-2, in the mode of angle measurement.	<div style="border: 1px solid black; padding: 5px;"> V ↑ : 81° 54' 21" HR : 157° 33' 58" TILT V/% R/L P2 ↑ </div>
② Press [F3] (L/R) .The mode Horizontal angle Right (HR) Switches to (HL) mode. ③ Measure as HL mode.	<div style="border: 1px solid black; padding: 5px;"> V ↑ : 81° 54' 21" HL : 157° 33' 58" TILT V/% R/L P2 ↑ </div>

4.3 Setting Horizontal Angle

1. Setting by Holding the Angle

Make sure the mode is angle measurement

Operation Procedure	Display
① Set the required horizontal angle, using Horizontal tangent screw	<div style="border: 1px solid black; padding: 5px;"> V ↑ : 81° 54' 21" HR : 10° 00' 00" OSET HOLD HSET P1 ↓ </div>
② Press the [F2] (HOLD) key	<div style="border: 1px solid black; padding: 5px;"> H ANGLE HOLD HR : 10° 00' 00" >SET ? --- --- [YES] [NO] </div>
③ Aim at the target, if need to return to the previous mode,press the [F4] (NO) Key	
④ Press the [F3] (YES) key to finish holding the horizontal angle.The display returns back to normal angle measurement mode.	<div style="border: 1px solid black; padding: 5px;"> V ↑ : 81° 54' 21" HR : 10° 00' 00" OSET HOLD HSET P1 ↓ </div>

2. Setting Horizontal Angle from the Keys

Make sure the mode is Angle measurement

Operation Procedure	Display
① Aim at the target	<div style="border: 1px solid black; padding: 5px;"> V ↑ : 81° 54' 21" HR : 10° 00' 00" OSET HOLD HSET P1 ↓ </div>
② Press the [F3] (HSET) key	<div style="border: 1px solid black; padding: 5px;"> H ANGLE SET (DEG) HR: = 1234 5678 90. - ENTER </div>
③ Input the required horizontal angle by pressing [F1] (Input) Example: 150°10'20" (Input 150.1020) Press [F4] (Enter) after inputting numbers. It returns to normal mode of angle measurement.	<div style="border: 1px solid black; padding: 5px;"> H ANGLE SET (DEG) HR: =150.1020 1234 5678 90. - ENTER </div> <div style="border: 1px solid black; padding: 5px;"> V ↑ : 81° 54' 21" HR : 150° 10' 20" OSET HOLD HSET P1 ↓ </div>

4.4 Vertical Angle Percent Grade (%) Mode

Make sure the mode is Angle measurement

Operation Procedure	Display
① Press [F4] (P↓) to get the function on P2	<div style="border: 1px solid black; padding: 5px;"> V ↑ : 81° 54' 21" HR : 150° 10' 20" OSET HOLD HSET P1 ↓ </div> <div style="border: 1px solid black; padding: 5px;"> TILT V/% R/L P2 ↑ </div>
② Press [F3] (V%) The display mode switches when pressing the [F3] (V%) key every time. While the measurement is carried out over ±45°(±100%) from the horizontal, the display shows <OUT>.	<div style="border: 1px solid black; padding: 5px;"> V ↑ : 81° 54' 21" HL : 202° 26' 02" TILT V/% R/L P2 ↑ </div>

4.5 Compasses (vertical angle) (Refer to 8.3)

Vertical angle is displayed as shown below:

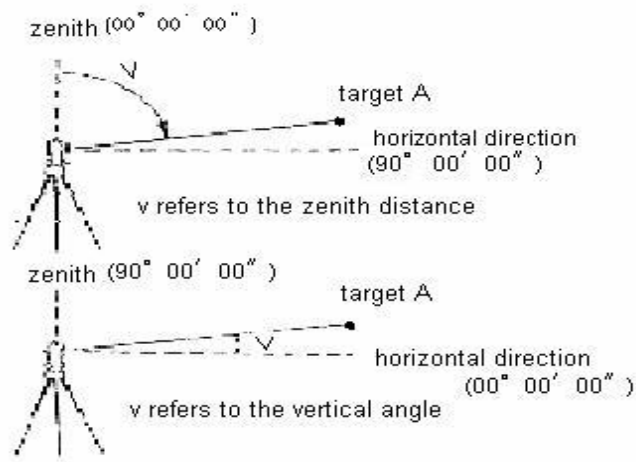

4.6 Remeasuring Horizontal Angle

Make sure the mode is Angle measurement

Operation Procedure	Display
<p>① Press [A] to get into the mode of Horizontal Angle Remeasurement</p>	<div style="border: 1px solid black; padding: 5px; margin-bottom: 10px;"> V ↑ : 81° 54' 21" HR : 150° 10' 20" OSET HOLD HSET P1 ↓ </div> <div style="border: 1px solid black; padding: 5px;"> HR : 157° 33' 58" 0 Sum : 0° 00' 00" Average: 0° 00' 00" >Sight A ? ENTER </div>
<p>② Aim at the Target A</p> <p>Press [F4] (ENTER) (one time) to set the reading of A as : 0°00'00"</p>	<div style="border: 1px solid black; padding: 5px;"> HR : 0° 00' 00" 0 Sum : 0° 00' 00" Average : 0° 00' 00" >Sight B ? ENTER </div>
<p>③ Aim at the Target B by Horizontal Tangent and Clamp Screws</p> <p>Press [F4] (ENTER) (one time) to remain the horizontal angle and it will be saved</p>	<div style="border: 1px solid black; padding: 5px;"> HR : 10° 00' 00" 1 Sum : 10° 00' 00" Average: 10° 00' 00" >Sight A ? ENTER </div>

<p>④ Aim at the Target A again</p> <p>Press [F4] (ENTER) (one time) to set the reading of A as : 0°00'00".(It begins the first remeasurement.)</p>	<table border="1" style="width: 100%;"> <tr><td>HR</td><td>:</td><td>0° 00' 00"</td><td>1</td></tr> <tr><td>Sum</td><td>:</td><td>10° 00' 00"</td><td></td></tr> <tr><td>Average:</td><td>:</td><td>10° 00' 00"</td><td></td></tr> <tr><td>>Sight</td><td></td><td>B ?</td><td>ENTER</td></tr> </table>	HR	:	0° 00' 00"	1	Sum	:	10° 00' 00"		Average:	:	10° 00' 00"		>Sight		B ?	ENTER
HR	:	0° 00' 00"	1														
Sum	:	10° 00' 00"															
Average:	:	10° 00' 00"															
>Sight		B ?	ENTER														
<p>⑤ Aim at the Target B again by Horizontal Tangent and Clamp Screws</p> <p>Press [F4] (ENTER) (one time) to remain and save the horizontal angle</p>	<table border="1" style="width: 100%;"> <tr><td>HR</td><td>:</td><td>10° 00' 02"</td><td>2</td></tr> <tr><td>Sum</td><td>:</td><td>20° 00' 02"</td><td></td></tr> <tr><td>Average:</td><td>:</td><td>10° 00' 01"</td><td></td></tr> <tr><td>>Sight</td><td></td><td>A ?</td><td>ENTER</td></tr> </table>	HR	:	10° 00' 02"	2	Sum	:	20° 00' 02"		Average:	:	10° 00' 01"		>Sight		A ?	ENTER
HR	:	10° 00' 02"	2														
Sum	:	20° 00' 02"															
Average:	:	10° 00' 01"															
>Sight		A ?	ENTER														
<p>⑥ Repeat step ④~⑤ to do the required remeasurement</p>																	
<ul style="list-style-type: none"> ● The remeasure times is limited,the Max is 9. It will show “times over” if more remeasurement done. ● When remeasuring, if the present value – the last average value ≥30",it will display (E-08) .Press [ESC]to escape,and try again from step ①. 																	

5. DISTANCE MEASUREMENT

Please confirm the cable can be connected with our Distance Meter before measurement.

Make sure the mode is Angle measurement

Operation Procedure	Display																				
<p>① Press  to enter into the mode of distance measurement</p>	<table border="1" style="width: 100%;"> <tr><td>V ↑ :</td><td>81° 54' 21"</td></tr> <tr><td>HR :</td><td>157° 33' 58"</td></tr> <tr><td>SD :</td><td>0.000m</td></tr> <tr><td>CT</td><td>TR</td><td>SD/HD</td><td>STOP</td></tr> </table>	V ↑ :	81° 54' 21"	HR :	157° 33' 58"	SD :	0.000m	CT	TR	SD/HD	STOP										
V ↑ :	81° 54' 21"																				
HR :	157° 33' 58"																				
SD :	0.000m																				
CT	TR	SD/HD	STOP																		
<p>② Aim at Prism center.</p> <p>③ Press [F1] (CT) to start Fine Measurement.</p> <p>Press [F2] (TR) to start Tracking Measurement.</p>	<table border="1" style="width: 100%;"> <tr><td>V ↑ :</td><td>81° 54' 21"</td></tr> <tr><td>HR :</td><td>157° 33' 58"</td></tr> <tr><td>SD :</td><td>10.000m</td></tr> <tr><td>CT</td><td>TR</td><td>SD/HD</td><td>STOP</td></tr> </table> <table border="1" style="width: 100%;"> <tr><td>V ↑ :</td><td>81° 54' 21"</td></tr> <tr><td>HR :</td><td>157° 33' 58"</td></tr> <tr><td>SD :</td><td>10.000m</td></tr> <tr><td>CT</td><td>TR</td><td>SD/HD</td><td>STOP</td></tr> </table>	V ↑ :	81° 54' 21"	HR :	157° 33' 58"	SD :	10.000m	CT	TR	SD/HD	STOP	V ↑ :	81° 54' 21"	HR :	157° 33' 58"	SD :	10.000m	CT	TR	SD/HD	STOP
V ↑ :	81° 54' 21"																				
HR :	157° 33' 58"																				
SD :	10.000m																				
CT	TR	SD/HD	STOP																		
V ↑ :	81° 54' 21"																				
HR :	157° 33' 58"																				
SD :	10.000m																				
CT	TR	SD/HD	STOP																		
<p>④ Press[F3] (SD/HD) to switch HD/SD/HD</p> <p>Press [F4] (STOP) to stop measuring</p>	<table border="1" style="width: 100%;"> <tr><td>V ↑ :</td><td>81° 54' 21"</td></tr> <tr><td>HD :</td><td>30.216m</td></tr> <tr><td>SD :</td><td>130.216m</td></tr> <tr><td>CT</td><td>TR</td><td>SD/HD</td><td>STOP</td></tr> </table>	V ↑ :	81° 54' 21"	HD :	30.216m	SD :	130.216m	CT	TR	SD/HD	STOP										
V ↑ :	81° 54' 21"																				
HD :	30.216m																				
SD :	130.216m																				
CT	TR	SD/HD	STOP																		

6. Distance Measurement through the crossline in the telescope

Through the sightline (up/down or left/right) in the telescope to measure the distance between the target and the instrument. (Accuracy $\leq 0.4\%D$)

- (1) Place the instrument at point A, and place the leveling staff at B.
- (2) Read the intercepted distance of the crossline (up/down or left / right) on the leveling staff as "d".
- (3) The horizontal Distance between A and B is D ($D = 100 \times d$.)

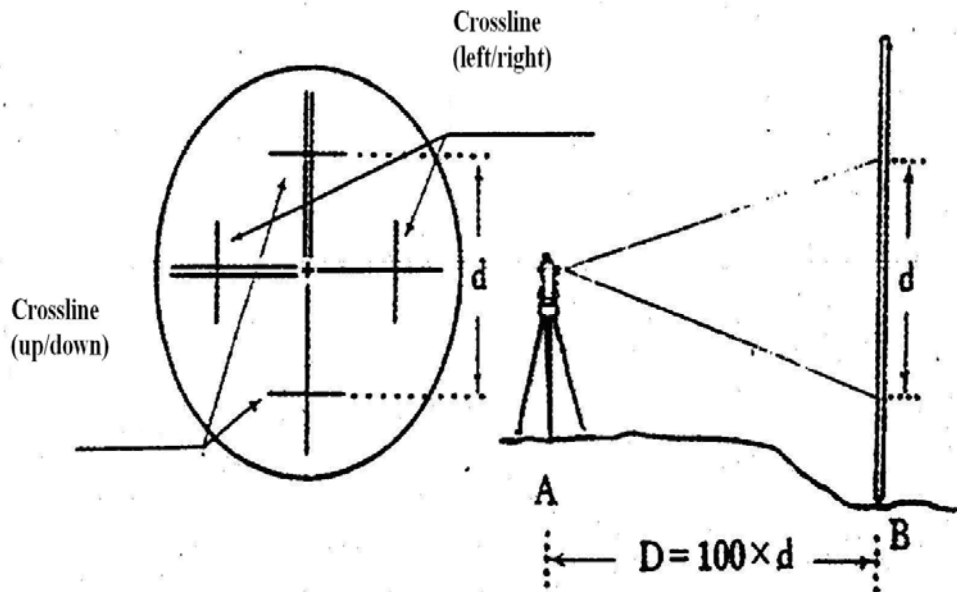

Note: 100 means the Stadia Proportion Constant of the instrument. (But because of such a low accuracy it can not be used to measure distance which requires high accuracy.)

7. Laser Measurement

Attention: Please don't watch the laser with eyes directly, when it is turned on!

7.1 Orientation Measurement

Find out the other points on the line of the two known points, which should be based on the known two points, this is Laser Orientation Measurement.

Steps as below:

1. Leveling the instrument, then power on
2. Aim at the target through the horizontal Tangent & Clamp Screws. Turn on the laser. The other points can be found out with a board which can make the laser focus together.

7.2 Angle Designment

Angle Designment is based on the line of two points, then design a horizontal angle according with the requirement.

Steps as below:

1. Leveling the instrument, then power on. This must be done on a fiducial point.
2. Aim at another fiducial point carefully, and set the horizontal angle as $0^{\circ}00'00''$.
3. Move the telescope to make the horizontal angle be the required value. Turn the laser on, the laser and the fiducial line will make up an angle.

7.3 Zeith Measurement

Set a point as a standard, the laser will be set up vertically, this is Zeith Measurement.

Steps as below:

1. Take away the eyepiece, fit on the diagonal eyepiece, and locked.
2. Leveling the instrument, then power on. This must be done on a fiducial point.
3. Circumgyrate the telescope to make the vertical angle to $0^{\circ}00'00''$, turn the laser on. Then move the focusing screw to make the facula minimum, loosen the horizontal clamp screw, move the telescope, the geometry center of the facula's moving track is the Vertical Direction.

7.4 Level Measurement

1. Leveling the instrument, then power on..
2. Lock the telescope after it is on the horizontal direction, aim at the target carefully. Turn on the laser, the red laser line can be used as level line.

8. Parameter Setting Up

8.1 Enter into Setting up Parameter

Go to the mode of angle measurement

Operation Procedure	Display
① Press [MENU] to enter into menu 2-1	<div style="border: 1px solid black; padding: 5px;"> <p>MENU 2-1</p> <p>F1: LASER UP[OFF]</p> <p>F2: LCD[OFF]</p> <p>F3: CONTRAST ADJ P ↓</p> </div>
② Press [F4] (P↓) to enter into menu 2-2	<div style="border: 1px solid black; padding: 5px;"> <p>MENU 2-2</p> <p>F1: SET</p> <p>F2: LASER DOWN[OFF]</p> <p>F3: EXIT P ↑</p> </div>
③ Press [F1] (SET) to enter into the SET MENU 3-1	<div style="border: 1px solid black; padding: 5px;"> <p>SET MENU 3-1</p> <p>F1: POWER AUTO[OFF]</p> <p>F2: CMPS[V ↑ :]</p> <p>F3: TILT[OFF] P ↓</p> </div>

④ Press [F4] (P↓) to enter into SET MENU 3-2	<div style="border: 1px solid black; padding: 5px;"> SET MENU 3-2 F1: ANGLE UNIT[DEG] F2: READ[1"] F3: DIST. UNIT[m] P ↓ </div>
⑤ Press [F4] (P↓) to enter into SET MENU 3-3	<div style="border: 1px solid black; padding: 5px;"> SET MENU 3-3 F1: SAVE AND EXIT P ↓ </div>

8.2 Setting up Power off Automatically

[Example]: Change Power ON to OFF on the mode of power off automatically

(Initial setting: [ON])

Operation Procedure	Display
① Make sure is the SET MENU 3-1	<div style="border: 1px solid black; padding: 5px;"> SET MENU 3-1 F1: POWER AUTO[ON] F2: CMPS[V ↑ :] F3: TILT[ON] P ↓ </div>
② Press [F1] to change [ON] to [OFF]	<div style="border: 1px solid black; padding: 5px;"> SET MENU 3-1 F1: POWER AUTO[OFF] F2: CMPS[V ↑ :] F3: TILT[ON] P ↓ </div>

8.3 Setting up Position 0(Vertical Angle)

[Example]: Change position 0 (Vertical angle) [V↑:] to [V→:] (Initial setting: [V↑:])

Operation Procedure	Display
① Make sure is the SET MENU 3-1	<div style="border: 1px solid black; padding: 5px;"> SET MENU 3-1 F1: POWER AUTO[ON] F2: CMPS[V ↑ :] F3: TILT[ON] P ↓ </div>
② Press [F2] to change [V↑:] to [V→:] V↑ : Zenith distance V→: Height angle	<div style="border: 1px solid black; padding: 5px;"> SET MENU 3-1 F1: POWER AUTO[ON] F2: CMPS[V→:] F3: TILT[ON] P ↓ </div>

8.4 Setting up Compensator

[Example]: Change compensator from [ON] to [OFF] (Initial setting: [ON])

Operation Procedure	Display
① Make sure is the SET MENU 3-1	<div style="border: 1px solid black; padding: 5px;"> SET MENU 3-1 F1: POWER AUTO[ON] F2: CMPS[V ↑ :] F3: TILT[ON] P ↓ </div>
② Press [F3] to change [ON] to [OFF]	<div style="border: 1px solid black; padding: 5px;"> SET MENU 3-1 F1: POWER AUTO[ON] F2: CMPS[V ↑ :] F3: TILT[OFF] P ↓ </div>

8.5 Setting up Angle Unit

[Example]: Change angle unit from [Degree] to [MIL] (Initial setting: [MIL])

Operation Procedure	Display
① Make sure is the SET MENU 3-2	<div style="border: 1px solid black; padding: 5px;"> SET MENU 3-2 F1: ANGLE UNIT[DEG] F2: READ[1"] F3: DIST. UNIT[m] P ↓ </div>
② Press [F1] to change [degree] to [MIL] One time: [MIL] Two times: [GON]	<div style="border: 1px solid black; padding: 5px;"> SET MENU 3-2 F1: ANGLE UNIT[MIL] F2: READ[1"] F3: DIST. UNIT[m] P ↓ </div>

8.6 Setting up Minimum Reading

[Example]: Change minimum reading from[1"] to [5"] (Initial setting: [1"])

Operation Procedure	Display
① Make sure is the SET MENU 3-2	<div style="border: 1px solid black; padding: 5px;"> SET MENU 3-2 F1: ANGLE UNIT[DEG] F2: READ[1"] F3: DIST. UNIT[m] P ↓ </div>

<p>② Press [F2] to change [1"]to [5"]</p> <p>One time: [5"] Two times: [10"] Three times: [20"]</p>	<table border="1"> <tr> <td>SET MENU</td> <td>3-2</td> </tr> <tr> <td>F1: ANGLE UNIT[MIL]</td> <td></td> </tr> <tr> <td>F2: READ[5"]</td> <td></td> </tr> <tr> <td>F3: DIST. UNIT[m]</td> <td>P ↓</td> </tr> </table>	SET MENU	3-2	F1: ANGLE UNIT[MIL]		F2: READ[5"]		F3: DIST. UNIT[m]	P ↓
SET MENU	3-2								
F1: ANGLE UNIT[MIL]									
F2: READ[5"]									
F3: DIST. UNIT[m]	P ↓								

8.7 Setting up Distance Unit

[Example]: Change distance unit from [m]to [ft] (Initial setting: [m])

Operation Procedure	Display								
<p>① Make sure is the SET MENU 3-2</p>	<table border="1"> <tr> <td>SET MENU</td> <td>3-2</td> </tr> <tr> <td>F1: ANGLE UNIT[DEG]</td> <td></td> </tr> <tr> <td>F2: READ[1"]</td> <td></td> </tr> <tr> <td>F3: DIST. UNIT[m]</td> <td>P ↓</td> </tr> </table>	SET MENU	3-2	F1: ANGLE UNIT[DEG]		F2: READ[1"]		F3: DIST. UNIT[m]	P ↓
SET MENU	3-2								
F1: ANGLE UNIT[DEG]									
F2: READ[1"]									
F3: DIST. UNIT[m]	P ↓								
<p>② Press [F3] to change [m] to [ft]</p>	<table border="1"> <tr> <td>SET MENU</td> <td>3-2</td> </tr> <tr> <td>F1: ANGLE UNIT[DEG]</td> <td></td> </tr> <tr> <td>F2: READ[1"]</td> <td></td> </tr> <tr> <td>F3: DIST. UNIT[ft]</td> <td>P ↓</td> </tr> </table>	SET MENU	3-2	F1: ANGLE UNIT[DEG]		F2: READ[1"]		F3: DIST. UNIT[ft]	P ↓
SET MENU	3-2								
F1: ANGLE UNIT[DEG]									
F2: READ[1"]									
F3: DIST. UNIT[ft]	P ↓								

8.8 Setting up Saving

Complete this step after the above setting steps done,or those set won't be changed.

Operation Procedure	Display								
<p>① Make sure is the SET MENU 3-3</p>	<table border="1"> <tr> <td>SET MENU</td> <td>3-3</td> </tr> <tr> <td>F1: SAVE AND EXIT</td> <td></td> </tr> <tr> <td></td> <td>P ↓</td> </tr> </table>	SET MENU	3-3	F1: SAVE AND EXIT			P ↓		
SET MENU	3-3								
F1: SAVE AND EXIT									
	P ↓								
<p>② Press [F1] to save setting and then escape.</p>	<table border="1"> <tr> <td>MENU</td> <td>2-2</td> </tr> <tr> <td>F1: SET</td> <td></td> </tr> <tr> <td>F2: LASER DOWN[OFF]</td> <td></td> </tr> <tr> <td>F3: EXIT</td> <td>P ↑</td> </tr> </table>	MENU	2-2	F1: SET		F2: LASER DOWN[OFF]		F3: EXIT	P ↑
MENU	2-2								
F1: SET									
F2: LASER DOWN[OFF]									
F3: EXIT	P ↑								

- ② Confirm whether the bubble does is in the center by rotating the instrument 180°.If not, repeat step ①.
- ③ Turn the instrument 180° (200g) and adjust the third screw to center the bubble in the vial.

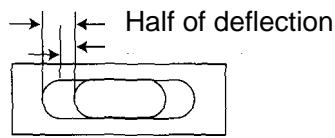

9.2 Check & Adjustment of Circular Vial

Check

No adjustment is necessary if the bubble of the circular vial is in the center after inspection and adjustment of the plate vial.

Adjustment

If the bubble of the circular vial is not in the center, bring the bubble to the center by using the adjusting pin to adjust two bubble-adjusting screws.

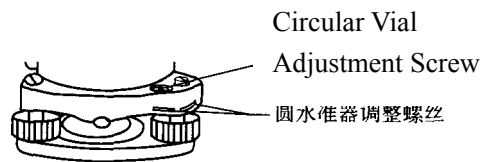

9.3 Check & Adjustment of Optical Plummet

Check

- ① Set the instrument on the tripod and place a piece of white paper with two perpendicular lines, then intersect drawn on it directly under the instrument. Adjust the leveling screws so that the center mark of the optical plummet coincides with the intersection point of the cross on the paper.
- ② Rotate the instrument around the vertical axis 180° (200g) observe whether the center mark position coincides with the intersection point of the cross. If the center mark always coincides with intersection point, no adjustment is necessary.

Otherwise, the following adjustment is necessary.

Adjustment

- ① Take off protective cover of the optical plummet, you may see four adjusting screws. Adjust four adjusting screws.

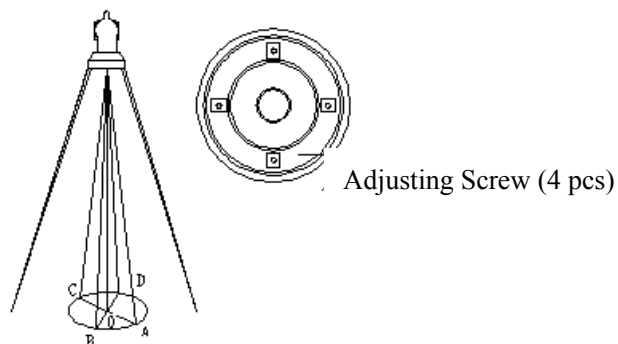

- ② Move woodscrew to make the center of optical plummet coincides with ground point.
- ③ Rotate the instrument around the vertical axis 180° (200g) observe whether the center mark position coincides with the intersection point of the cross. If the center mark always coincides with intersection point, no adjustment is necessary. Otherwise, repeat steps above mentioned.

9.4 Check & Adjustment of Inclination of Reticle

Check

- ① Set the instrument on a tripod and level it.
- ② Aim at target A with telescope (One point, 50m away).
- ③ Observe point A moves along the vertical line of the reticle or not by moving telescope up and down.. If so, no adjustment is necessary. If not so, then need to adjust the reticle.

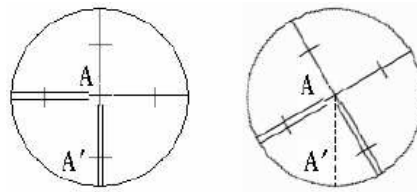

Adjustment

- ① Remove the eyepiece cover to expose the four reticle adjusting screws.
- ② Loosen the four reticle adjusting screws uniformly with an adjusting pin. Rotate the reticle around the sight line and align the vertical line of the reticle with point A. Tighten the reticle adjusting screws.
- ③ Repeat the inspection and adjustment to see if the adjustment is correct.

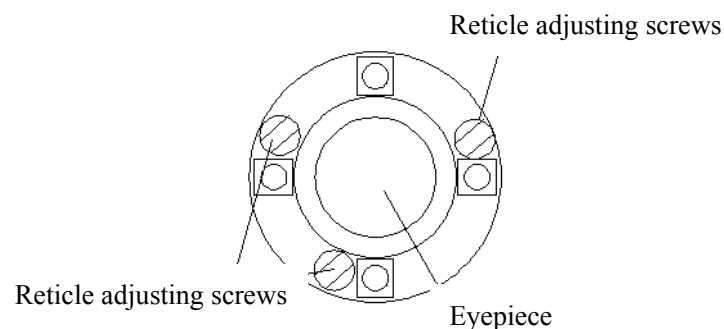

Note: Remember to check the index of the instrument after adjusting.

9.5 Check & Adjustment of discrepancy between twice collimation errors(C)

Check

- ① Set the instrument on a tripod and level it.
- ② Aim at cross line of the reticle of the collimator or a target away. Observe left position and right position.
- ③ Calculate difference after getting horizontal angle reading (left position) HI and (right

position)HR

$$C = (HI - HR \pm 180^\circ) / 2$$

If $C \leq 8''$, no adjustment is necessary; If $C > 8''$, follow these steps to adjust it.

Adjustment

- ① Rotate fine motion screw in the right position and make the reading is **HR + C**.
- ② Remove the eyepiece cover to adjust two adjusting screws, which makes reticle coincides with cross line of collimator or one target away.
- ③ Repeat check and adjustment until $C \leq 8''$.

9.6 Check & Adjustment of Vertical Index Difference (i angle)

※Inspect the item after finishing the inspection and adjustment of section 9.4 and 9.5.

Check

- ① Set the instrument on a tripod and level it.
- ② Sight object A in left position and read the Vertical angle value VI. Rotate the telescope. Sight object B in right position and read the Vertical angle value VR.
- ③ Calculating, $i = (VI + VR - 360^\circ) / 2$
- ④ If $i \leq 10''$, no adjustment is necessary. If $i > 10''$, adjust it.

Adjustment

Operation Procedure	Display
① Keep to press [F1] to power on until right screen occurs Loose [F1]	<div style="border: 1px solid black; padding: 5px; text-align: center;"> ADJUSTMENT MODE V ANGLE 0 SET TURN TELESCOPE </div>
② Rotate telescope and make vertical angle passing 0. Enter into the mode of V ANGLE 0 SET	<div style="border: 1px solid black; padding: 5px; text-align: center;"> V 0 POINT SET (STEP-1) V: 82° 06' 30" ----- SET </div>
③ Aim at target (left position). Press [F4] (SET)	<div style="border: 1px solid black; padding: 5px; text-align: center;"> V 0 POINT SET (STEP-2) V: 182° 06' 30" ----- SET </div>
④ Aim at target (right position). Press [F4](SET). Power on automatically.	
⑤ Finish adjustment Repeat, if not within standard.	

9.7 Check & Adjustment of the laser confocal and coaxial

※This step was done after finishing the inspection and adjustment of Item 9.4 and 9.5

● Laser confocal

Send the laser after aiming at the target, and then check the facula's diameter. It should be minimum. If it is not, loose the screw on the laser pedestal, and move the pedestal until the facula be smallest.

● Laser coaxial

The crossline should be in superposition with the facula after aiming at the target. Make the facula in the center of the crossline through the four screws on the pedestal.

10. Technical Index

Telescope	
Image	Erect
Magnification	30×
Effective aperture	47mm
Resolving power	3.75"
Minimum focus	1 m
Stadia ratio	100
Sight distance precision	≤0.4%D
Tube length	162mm
Angle Measurement	
Measuring method	photoelectric detection by incremental encoder
Diameter of circle	79mm
Minimum reading	1", 5", 10" Selectable
Measuring unit	360°, 400gon, 6400mil Selectable
Vertical angle 0°	Zenith 0°, Horizontal 0° Selectable
Vial	
Plate vial	30"/2mm
Circular vial	8'/2mm
Compensator	
System	Liquid-electric detection
Compensation range	±3'
Resolving power	1 "
Optical Plummet	
Image	Erect
Magnification	3×
Focusing range	0.3m~∞
Field of view	5°
Display	
Type	LCD, Four lines, digital

Data Communication	
Port	RS-232C
On-board Battery	
Power resource	Rechargeable Ni-H battery
Voltage	DC7.2V
Operation time	BDC 1800mAh(about 20 hours)
Laser	
Length of the wave	635nm
Power	10mW
Effective range(during daytime)	150m
Position error with the sight	≤5"
Power	DC3.3V
Working temperature	-10℃~+45℃
Operation Environment	
Operating temperature	-20℃~+45℃
Size & weight	
Dimension	180mm×166mm×355mm
Weight	6.5kg

11. Packing List

Carry case	1pc
Instrument	1pc
On-board battery	2pcs
Recharger	1pc
Plummet	1pc
Tool bag	1pc
Protection bag	1pc
Operationg manual	1pc